

"Water to Air c/w Desuperheater (PHW), as illustrated,"

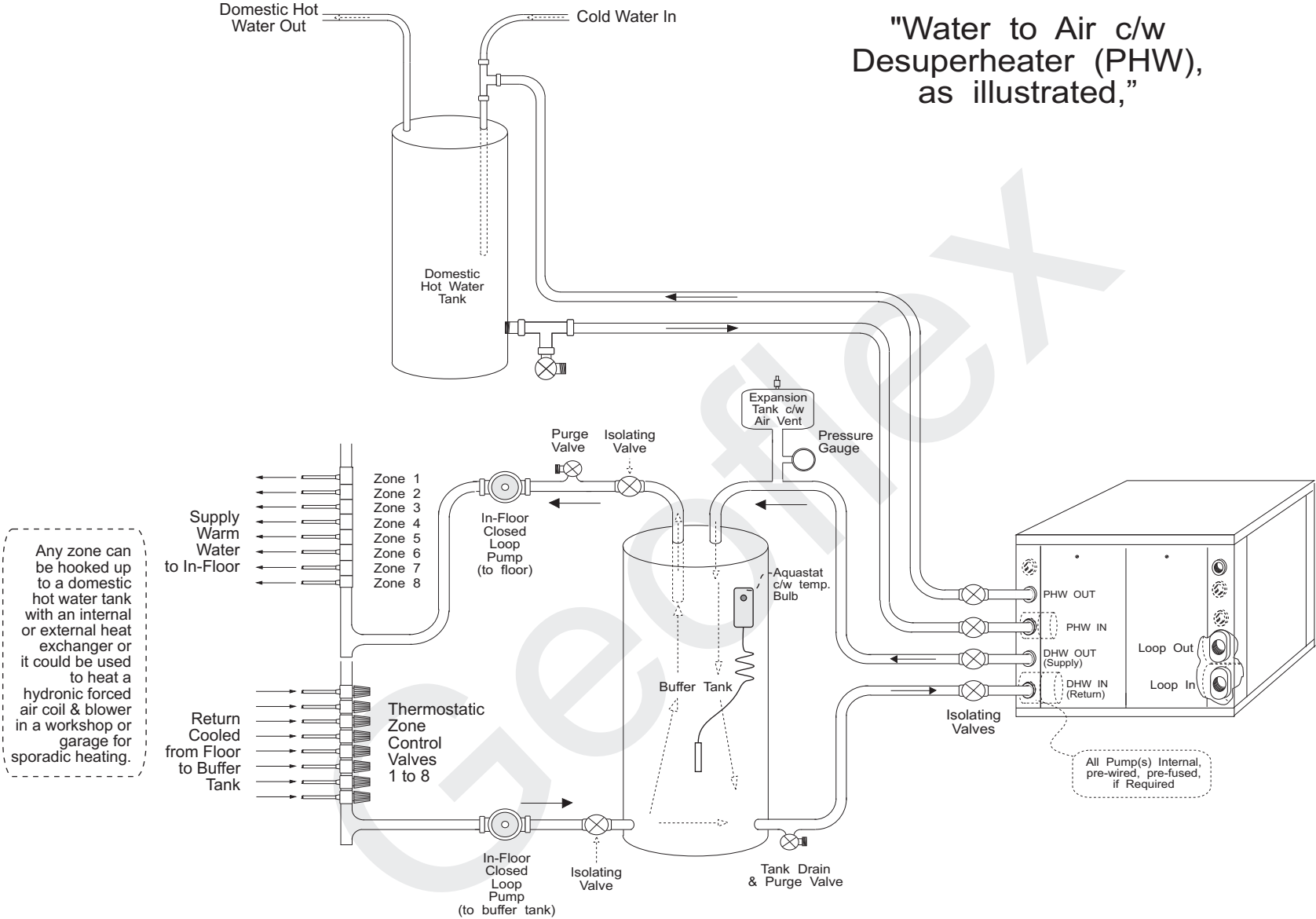

Any zone can be hooked up to a domestic hot water tank with an internal or external heat exchanger or it could be used to heat a hydronic forced air coil & blower in a workshop or garage for sporadic heating.

All Pump(s) Internal, pre-wired, pre-fused, if Required



Note: All Geoflex Systems are CSA (Canadian Standards Association) Approved

GF-INFLWW-a
 all rights reserved © Geoflex Systems Inc. 2006
 Due to ongoing research and development Geoflex reserves the right to change or alter specifications and configurations without notice!

Plant Office:
 517 McCormick Blvd., London, Ontario N5W 4C8
 Phone: 519.488.1653 Fax: 519.913.1259
 Email: plant@geoflexsystems.com

www.geoflexsystems.com

Administration Office:
 #1, 301 Pakwa Pl., Saskatoon, Sk, S7L 6A3
 Phone: 306.668.0090 Fax: 306.668.0049
 Email: admin@geoflexsystems.com

"Water to Water c/w
Desuperheater & Zoned
Hydronic Air Coil,
as illustrated.

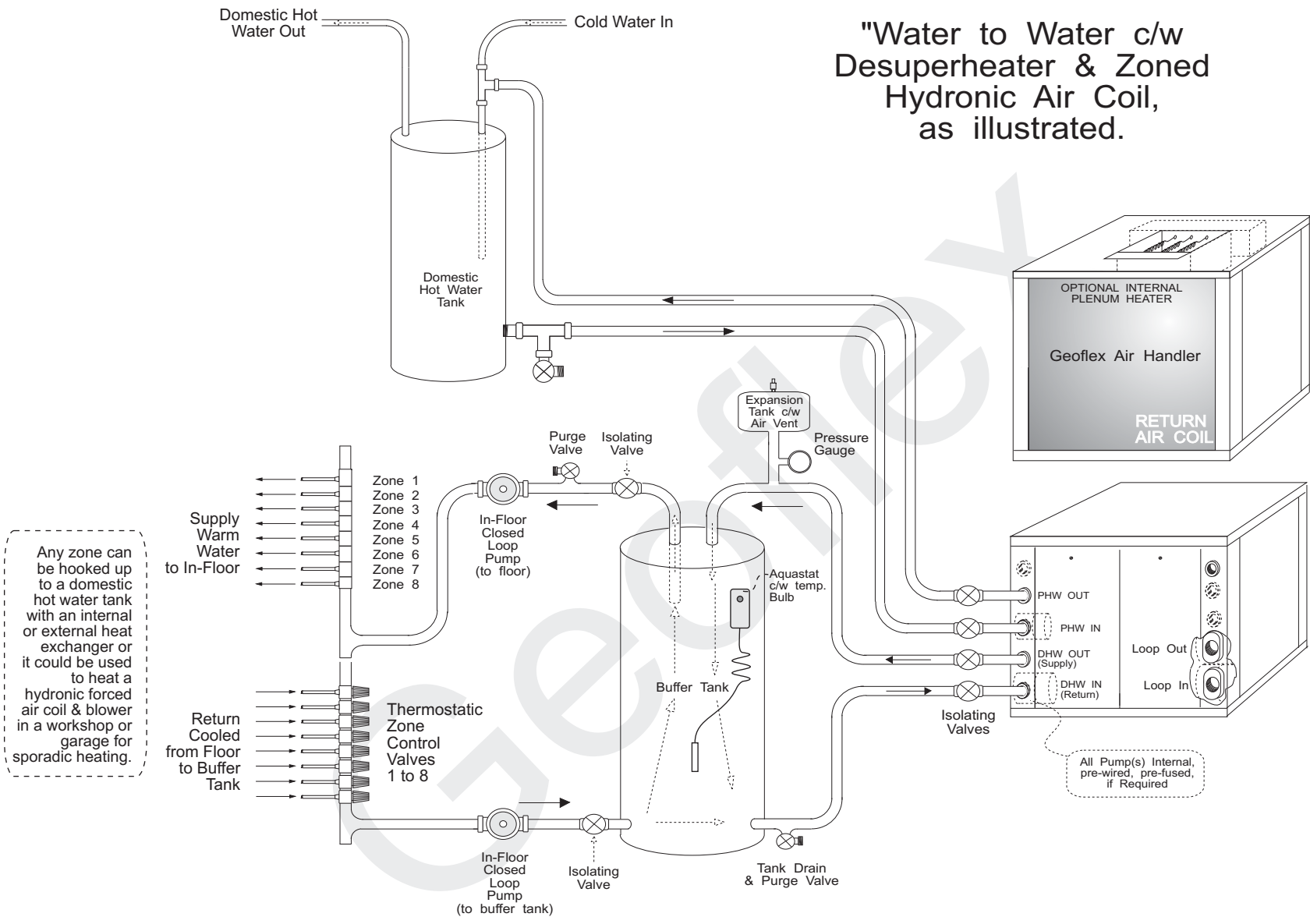

Any zone can be hooked up to a domestic hot water tank with an internal or external heat exchanger or it could be used to heat a hydronic forced air coil & blower in a workshop or garage for sporadic heating.

All Pump(s) Internal, pre-wired, pre-fused, if Required



Note: All Geoflex Systems are CSA (Canadian Standards Association) Approved
 GF-INFLWW-b
 all rights reserved © Geoflex Systems Inc. 2006
 Due to ongoing research and development Geoflex reserves the right to change or alter specifications and configurations without notice!

Plant Office:
 517 McCormick Blvd., London, Ontario N5W 4C8
 Phone: 519.488.1653 Fax: 519.913.1259
 Email: plant@geoflexsystems.com

Administration Office:
 #1, 301 Pakwa Pl., Saskatoon, Sk, S7L 6A3
 Phone: 306.668.0090 Fax: 306.668.0049
 Email: admin@geoflexsystems.com

www.geoflexsystems.com

"Water to Water c/w Desuperheater (PHW) & Indirect Hot Water Tank

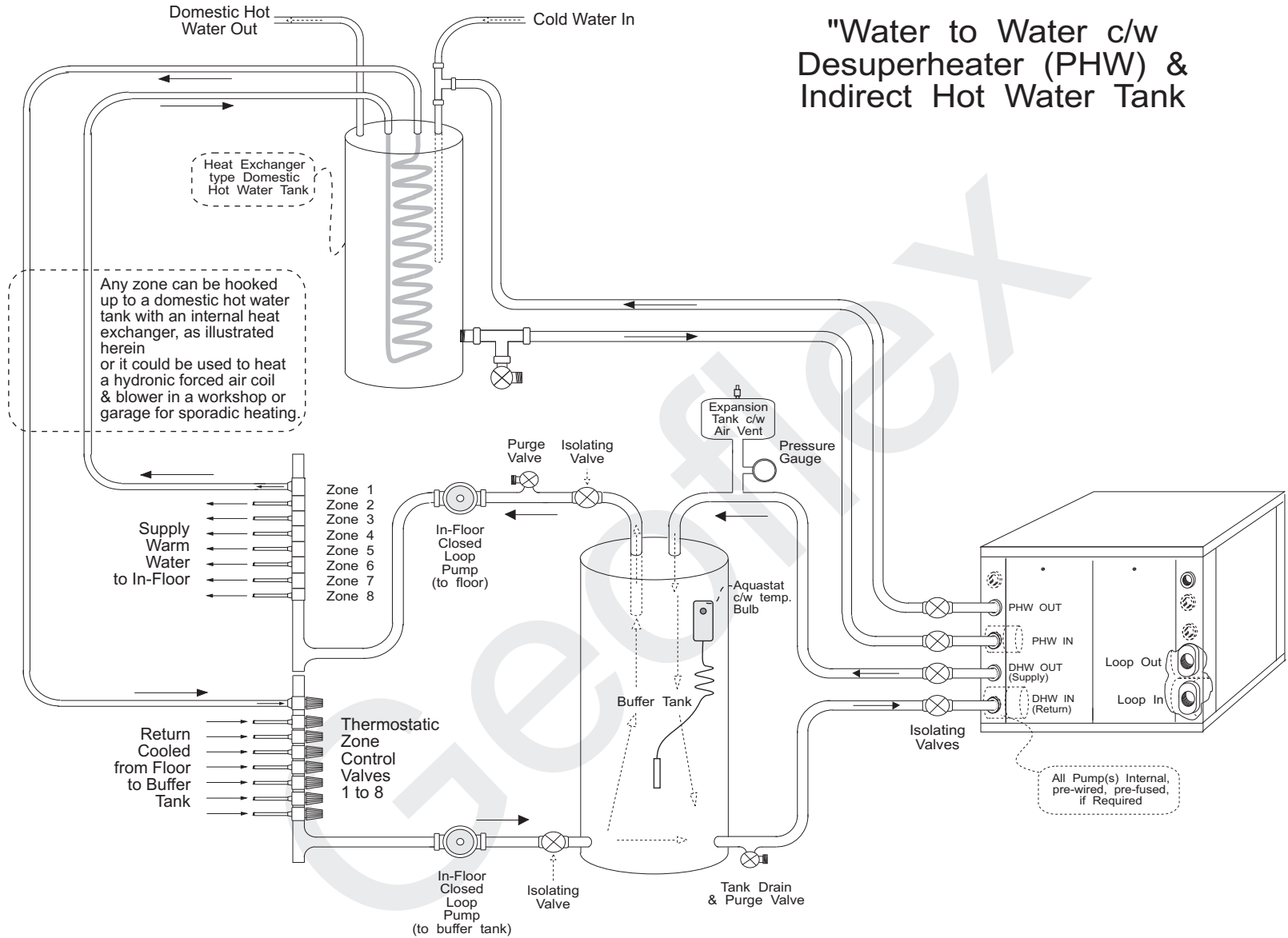

Note: All Geoflex Systems are CSA (Canadian Standards Association) Approved

GF-INFLWW-c
all rights reserved © Geoflex Systems Inc. 2006
Due to ongoing research and development Geoflex reserves the right to change or alter specifications and configurations without notice!

Plant Office:
517 McCormick Blvd., London, Ontario N5W 4C8
Phone: 519.488.1653 Fax: 519.913.1259
Email: plant@geoflexsystems.com

www.geoflexsystems.com

Administration Office:
#1, 301 Pakwa Pl., Saskatoon, Sk, S7L 6A3
Phone: 306.668.0090 Fax: 306.668.0049
Email: admin@geoflexsystems.com

"Water to Water c/w Demand Hot Water (DHW) Option & Indirect Buffer Tank, "A Triple Function System" & Desuperheater

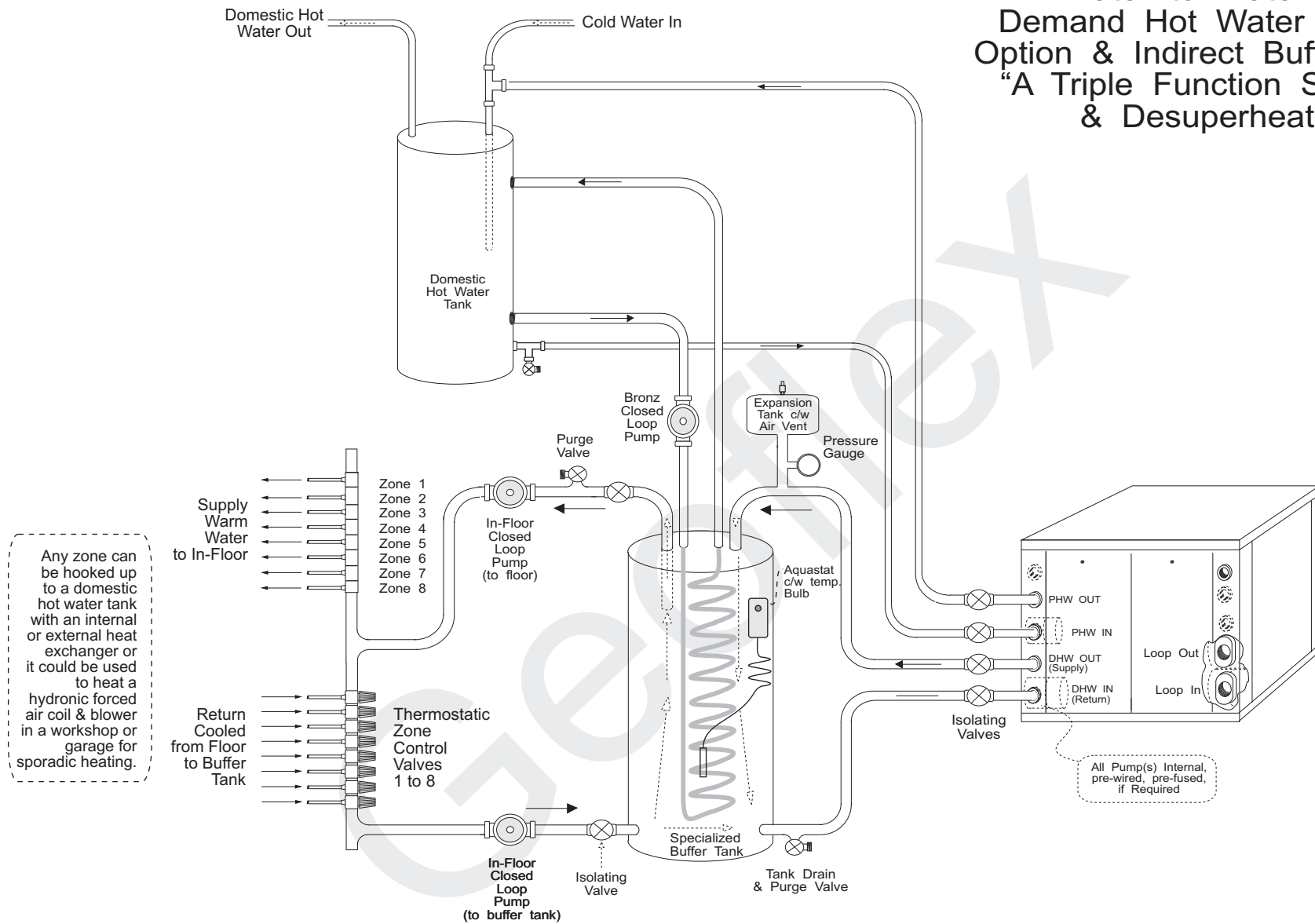

Note: All Geoflex Systems are CSA (Canadian Standards Association) Approved

www.geoflexsystems.com



GF-INFLWW-d

all rights reserved © Geoflex Systems Inc. 2006
 Due to ongoing research and development Geoflex reserves the right to change or alter specifications and configurations without notice!

Plant Office:

517 McCormick Blvd., London, Ontario N5W 4C8
 Phone: 519.488.1653 Fax: 519.913.1259
 Email: plant@geoflexsystems.com

Administration Office:

#1, 301 Pakwa Pl., Saskatoon, Sk, S7L 6A3
 Phone: 306.668.0090 Fax: 306.668.0049
 Email: admin@geoflexsystems.com